

BAG DUMP STATION

Automated Ingredient Systems Bag Dump Stations provide customers with a simple and economical way to introduce ingredients into their process. Units can be provided with a vent stub for connection to a central dust collection system, or with an integral pulse jet style collector. AIS Bag Dump Stations are designed to capture and remove airborne dust. The ergonomically correct design ensures that operators will be working at the correct height. Bar grates aid in preventing paper and other foreign materials from entering the process. Quick Clean style units have an access door in the hopper and removable baffles allowing the interior of the dump station to be cleaned quickly and easily for frequent product change over. The discharge of difficult to handle ingredients can be aided through the use of mechanical vibration, or aeration. When used with a MSV Vacuum Conveyor, the customer can easily and economically automate their ingredient delivery process.

FEATURES

Compact Design – Designed to occupy the least amount of floor space while providing the maximum amount of storage.

Quick Access Filters – Filter changes can be accomplished quickly and easily with no tools required.

Materials of construction – Units are constructed of carbon steel, 304 stainless steel, or aluminum. Internal welds are ground smooth and flush on food grade models.

Controls – Units are supplied with a NEMA 4 timer box that controls the integral dust collector.

Fan – Available with direct drive, cast aluminum, arrangement 4 fan.

Magnehelic gauge – Integral dust collection units are supplied with a magnehelic gauge to allow visual identification of filters status.

Additional Options – Vibrating screens for pre-scalping, magnetic grates, and transfer equipment to deliver ingredients to their final destination.



DIMENSIONS

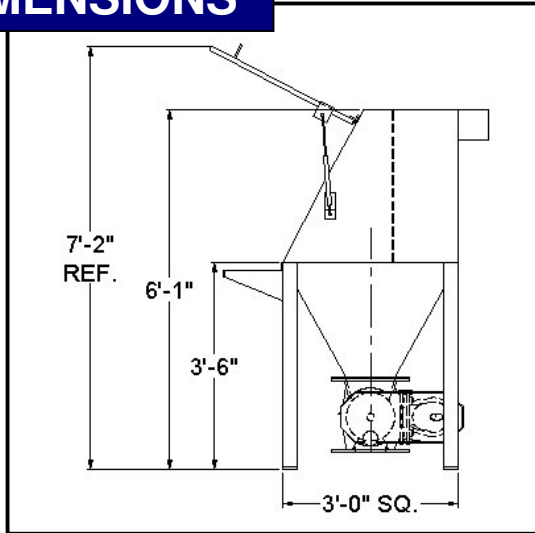

Non-filtered Bag Dump Station

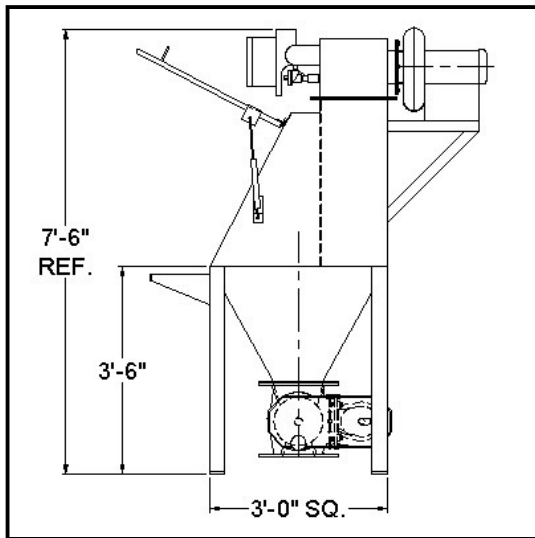

Filtered Bag Dump Station

OPTIONS

Level Indicator
 NEMA 9 controls
 Explosion proof motor
 Rotary Airlock
 Vibratory Feeder
 Pick-up pan
 Bag grate
 Fluidization Cones
 Impacting vibrator

Removable Filter Access Door



Twist Lock Design



INFORMATION

- Units are supplied standard with gas cylinders to assist operators in opening and closing the Bag Dump Station door.
- Removable internal baffles provide quick access to the filter elements from the front of the unit.
- Baffles can be removed by hand and require no tools.
- Bottom load filter elements allow fast and safe changing of filters.
- Magnehelic gauge alerts operators of the need to change filter elements.
- Magnetic and non-magnetic grates can be supplied to help prevent contamination by foreign materials.
- Optional control panel includes motor starter and other necessary items for a stand-alone package.

FILTRATION MEDIA

A variety of filtration media is available to meet the specific requirements of the ingredient being handled.

Elements:

Spun bond polyester
 PTFE membrane coated
 Various pleat configurations